

Installer's Guide

Condensing Units

4A7A6

ALL phases of this installation must comply with NATIONAL, STATE AND LOCAL CODES

IMPORTANT — This Document is customer property and is to remain with this unit. Please return to service information pack upon completion of work.

These instructions do not cover all variations in systems or provide for every possible contingency to be met in connection with the installation. Should further information be desired or should particular problems arise which are not covered sufficiently for the purchaser's purposes, the matter should be referred to your installing dealer or local distributor.

Note: The manufacturer recommends installing only approved matched indoor and outdoor systems. All of the manufacture's split systems are A.H.R.I. rated only with TXV/EEV indoor systems. Some of the benefits of installing approved matched indoor and outdoor split systems are maximum efficiency, optimum performance and the best overall system reliability.

Table of Contents

| | |
|--|----|
| Section 1. Safety..... | 2 |
| Section 2. Unit Location Considerations..... | 3 |
| Section 3. Unit Preparation..... | 5 |
| Section 4. Setting the Unit..... | 5 |
| Section 5. Refrigerant Line Considerations..... | 6 |
| Section 6. Refrigerant Line Routing..... | 7 |
| Section 7. Refrigerant Line Brazing..... | 8 |
| Section 8. Refrigerant Line Leak Check..... | 10 |
| Section 9. Evacuation..... | 11 |
| Section 10. Service Valves..... | 11 |
| Section 11. Electrical - Low Voltage..... | 13 |
| Section 12. Electrical - High Voltage..... | 16 |
| Section 13. Start Up..... | 17 |
| Section 14. System Charge Adjustment..... | 18 |
| Section 15. Checkout Procedures and Troubleshooting..... | 22 |

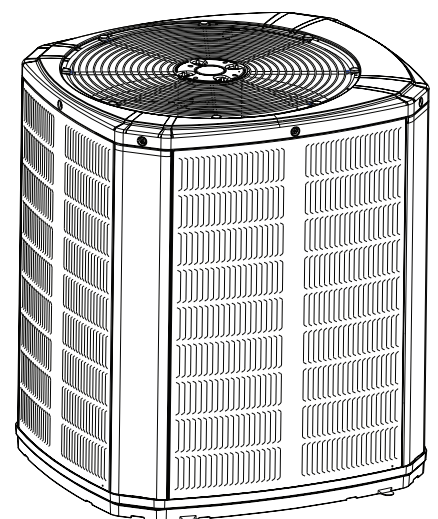

Section 1. Safety

WARNING

This information is intended for use by individuals possessing adequate backgrounds of electrical and mechanical experience. Any attempt to repair a central air conditioning product may result in personal injury and/or property damage. The manufacture or seller cannot be responsible for the interpretation of this information, nor can it assume any liability in connection with its use.

WARNING

These units use R-410A refrigerant which operates at 50 to 70% higher pressures than R-22. Use only R-410A approved service equipment. Refrigerant cylinders are painted a “Rose” color to indicate the type of refrigerant and may contain a “dip” tube to allow for charging of liquid refrigerant into the system. All R-410A systems use a POE oil that readily absorbs moisture from the atmosphere. To limit this “hygroscopic” action, the system should remain sealed whenever possible. If a system has been open to the atmosphere for more than 4 hours, the compressor oil must be replaced. Never break a vacuum with air and always change the driers when opening the system for component replacement. For specific handling concerns with R-410A and POE oil reference Retrofit Bulletins SS-APG006-EN and APP-APG011-EN.

WARNING

UNIT CONTAINS R-410A REFRIGERANT!
R-410A operating pressures exceed the limit of R-22. Proper service equipment is required. Failure to use proper service tools may result in equipment damage or personal injury.

SERVICE

USE ONLY R-410A REFRIGERANT AND APPROVED POE COMPRESSOR OIL.

WARNING

Extreme caution should be exercised when opening the Liquid Line Service Valve. Turn counterclockwise until the valve stem just touches the rolled edge. No torque is required. Failure to follow this warning will result in abrupt release of system charge and may result in personal injury and /or property damage.

WARNING

LIVE ELECTRICAL COMPONENTS!

During installation, testing, servicing, and troubleshooting of this product, it may be necessary to work with live electrical components. Failure to follow all electrical safety precautions when exposed to live electrical components could result in death or serious injury.

CAUTION

If using existing refrigerant lines make certain that all joints are brazed, not soldered.

CAUTION

Scroll compressor dome temperatures may be hot. Do not touch the top of compressor; it may cause minor to severe burning.

Section 2. Unit Location Considerations

2.1 Unit Dimensions and Weight

Table 2.1

| Unit Dimensions and Weight | | |
|----------------------------|----------------|--------------|
| Models | H x D x W (in) | Weight* (lb) |
| 4A7A6024G | 41 x 34 x 37 | 240 |
| 4A7A6036G | 45 x 34 x 37 | 245 |
| 4A7A6048G | 45 x 34 x 37 | 271 |
| 4A7A6060E/G | 45 x 34 x 37 | 275 |

* Weight values are estimated.

When mounting the outdoor unit on a roof, be sure the roof will support the unit's weight.

Properly selected isolation is recommended to alleviate sound or vibration transmission to the building structure.

Please refer to application bulletin APP-APG014-EN for detailed mounting information.

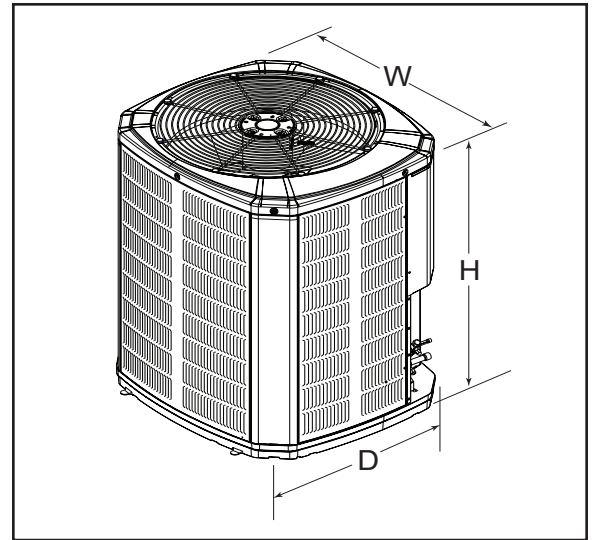

2.2 Refrigerant Piping Limits

1. The maximum length of refrigerant lines from outdoor to indoor unit should NOT exceed sixty (60) feet.
2. The maximum vertical change should not exceed twenty five (25) feet*.
3. Service valve connection diameters are shown in Table 5.1.

Note: For line lengths greater than sixty (60) feet, Refer to Refrigerant Piping Application Guide, SS-APG006-EN or Refrigerant Piping Software Program, 32-3312-03 (or latest revision).

* Restricted to maximum vertical change of 25 ft.

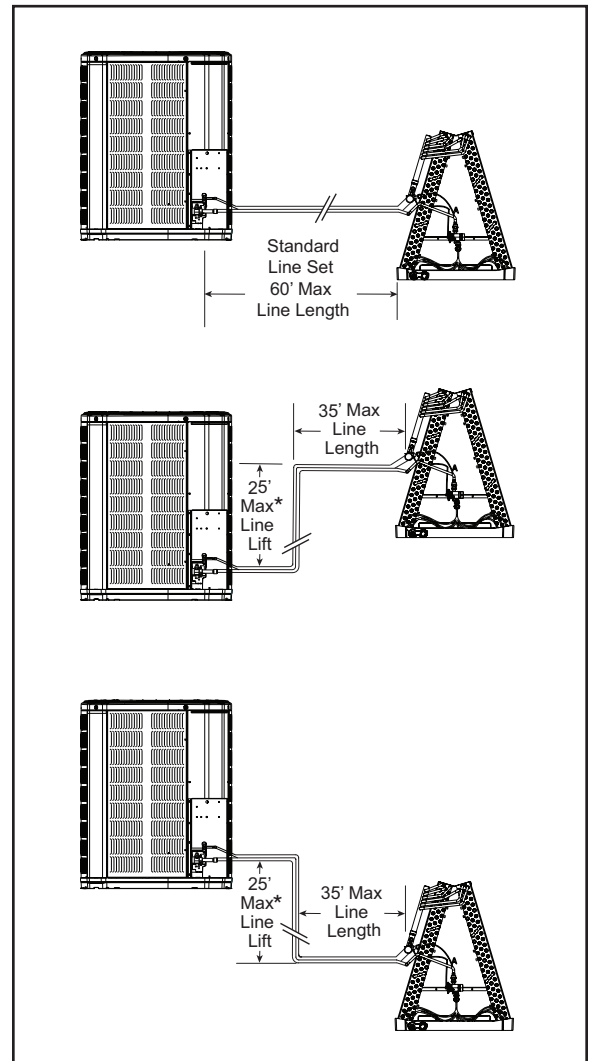

2.3 Suggested Locations for Best Reliability

Ensure the top discharge area is unrestricted for at least five (5) feet above the unit.

Three (3) feet clearance must be provided in front of the control box (access panels) and any other side requiring service.

Do not locate close to bedrooms as operational sounds may be objectionable.

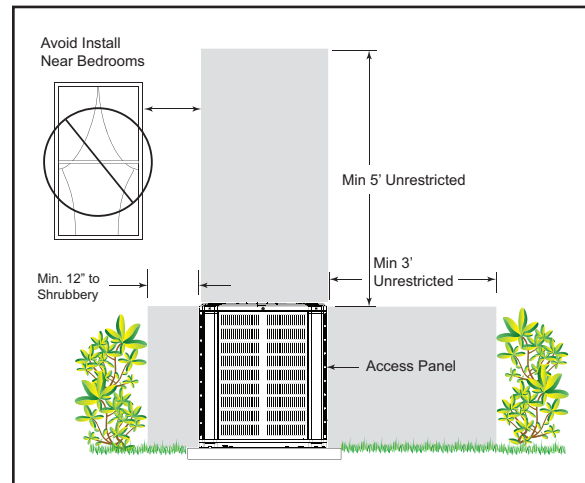

Position the outdoor unit a minimum of 12" from any wall or surrounding shrubbery to ensure adequate airflow.

Outdoor unit location must be far enough away from any structure to prevent excess roof runoff water from pouring directly on the unit.

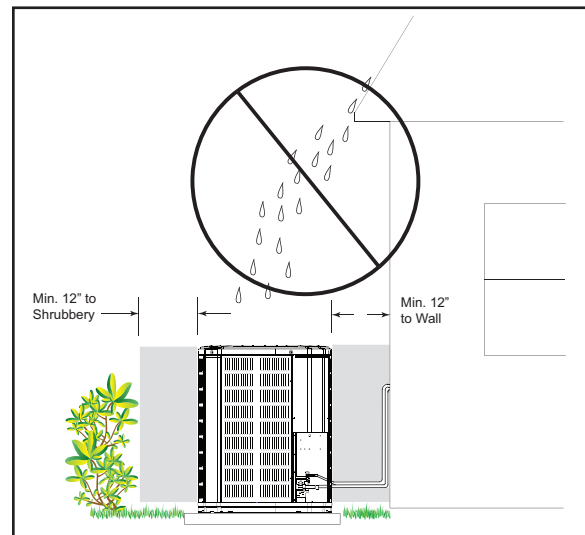

2.4 Coastal Considerations

If installed within one mile of salt water, including seacoasts and inland waterways, models without factory supplied Seacoast Salt Shields require the addition of BAYSEAC001 (Seacoast Kit) at installation time. Please refer to Application Guide SS-APB007-EN: *American Standard - Sea Coast Applications and Seacoast Corrosion Protection Bulletin UN-SVB11A-EN*.

Section 3. Unit Preparation

3.1 Prepare The Unit For Installation

STEP 1 - Check for damage and report promptly to the carrier any damage found to the unit.

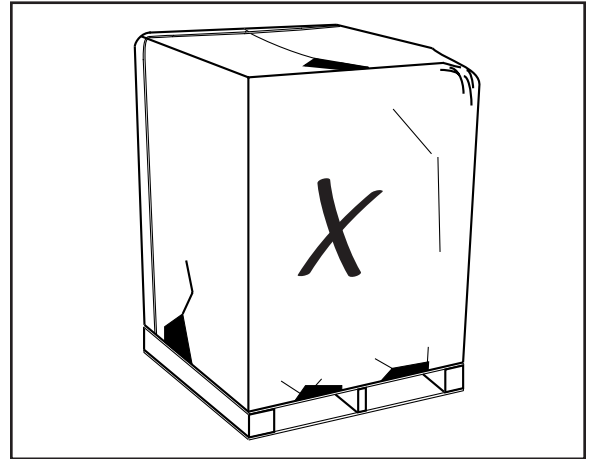

STEP 2 - To remove the unit from the pallet, remove tabs by cutting with a sharp tool.

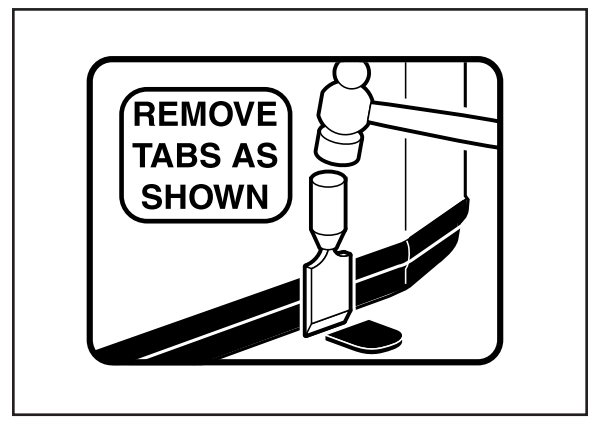

Section 4. Setting the Unit

4.1 Pad Installation

When installing the unit on a support pad, such as a concrete slab, consider the following:

- The pad should be at least 1" larger than the unit on all sides.
- The pad must be separate from any structure.
- The pad must be level.
- The pad should be high enough above grade to allow for drainage.
- The pad location must comply with National, State, and Local codes.

For other applications refer to Application Guide APP-APG014-EN.

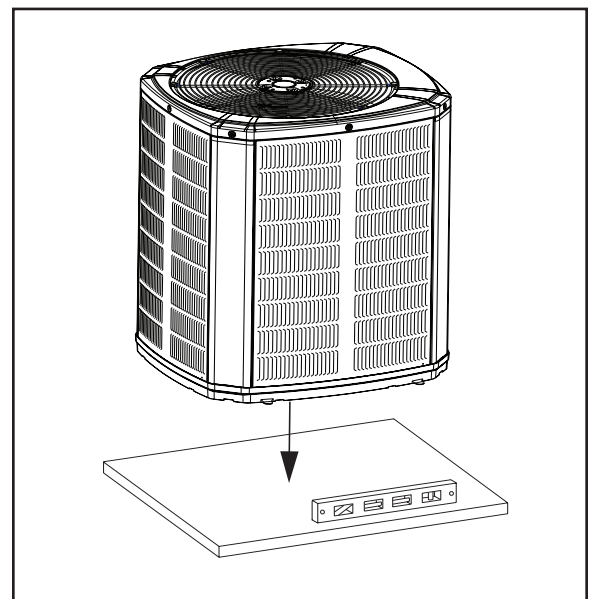

Section 5. Refrigerant Line Considerations

5.1 Refrigerant Line and Service Valve Connection Sizes

Table 5.1

| Model | Line Sizes | | Service Valve Connection Sizes | |
|-------------|------------|-------------|--------------------------------|------------------------|
| | Vapor Line | Liquid Line | Vapor Line Connection | Liquid Line Connection |
| 4A7A6024G | 5/8 | 3/8 | 5/8 | 3/8 |
| 4A7A6036G | 3/4 | 3/8 | 3/4 | 3/8 |
| 4A7A6048G | 7/8 | 3/8 | 7/8 | 3/8 |
| 4A7A6060E/G | 1-1/8 | 3/8 | 1-1/8 | 3/8 |

5.2 Factory Charge

American Standard Heating & Air Conditioning outdoor condensing units are factory charged with the system charge required for the outdoor condensing unit, fifteen (15) feet of tested connecting line, and the smallest indoor evaporative coil match. **If connecting line length exceeds fifteen (15) feet and/or a larger indoor evaporative coil is installed, then final refrigerant charge adjustment is necessary.**

5.3 Required Refrigerant Line Length

Determine required line length and lift. You will need this later in STEP 2 of Section 14.

Total Line Length = _____ Ft.

Total Vertical Change (lift) = _____ Ft.

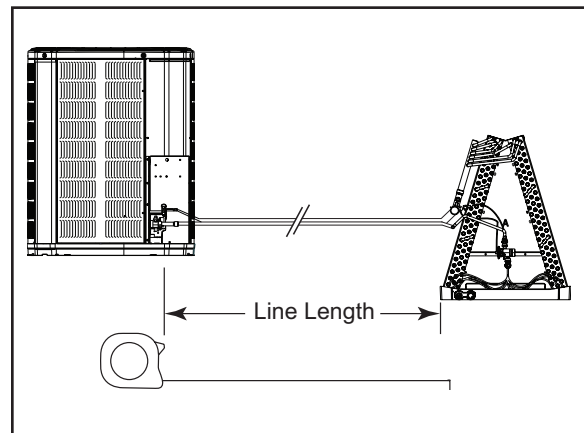

5.4 Refrigerant Line Insulation

Important: The Vapor Line must always be insulated. DO NOT allow the Liquid Line and Vapor Line to come in direct (metal to metal) contact.

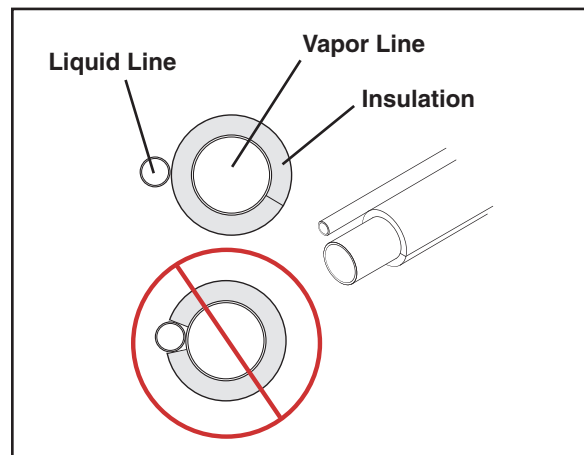

5.5 Reuse Existing Refrigerant Lines

⚠ CAUTION

If using existing refrigerant lines make certain that all joints are brazed, not soldered.

For retrofit applications, where the existing indoor evaporator coil and/or refrigerant lines will be used, the following precautions should be taken:

- Ensure that the indoor evaporator coil and refrigerant lines are the correct size.
- Ensure that the refrigerant lines are free of leaks, acid, and oil.

Important: For more information see publication numbers SS-APG006-EN and APP-APG012-EN.

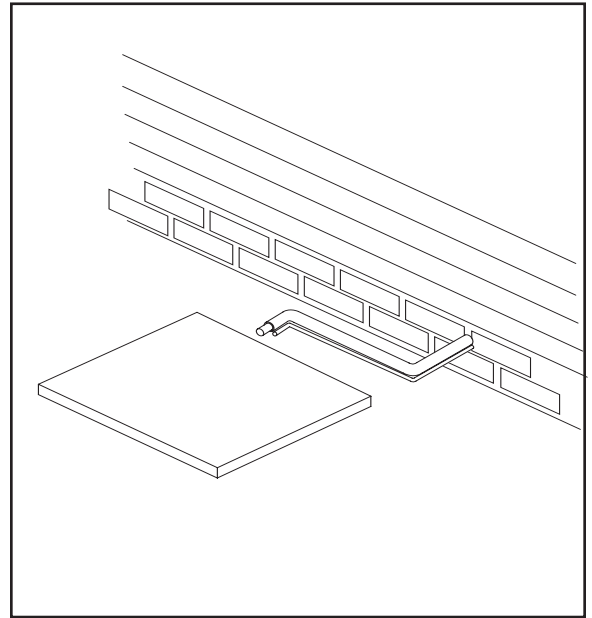

Section 6. Refrigerant Line Routing

6.1 Precautions

Important: Take precautions to prevent noise within the building structure due to vibration transmission from the refrigerant lines.

Comply with National, State, and Local Codes when isolating line sets from joists, rafters, walls, or other structural elements.

For Example:

- When the refrigerant lines have to be fastened to floor joists or other framing in a structure, use isolation type hangers.
- Isolation hangers should also be used when refrigerant lines are run in stud spaces or enclosed ceilings.
- Where the refrigerant lines run through a wall or sill, they should be insulated and isolated.
- Isolate the lines from all ductwork.
- Minimize the number of 90° turns.

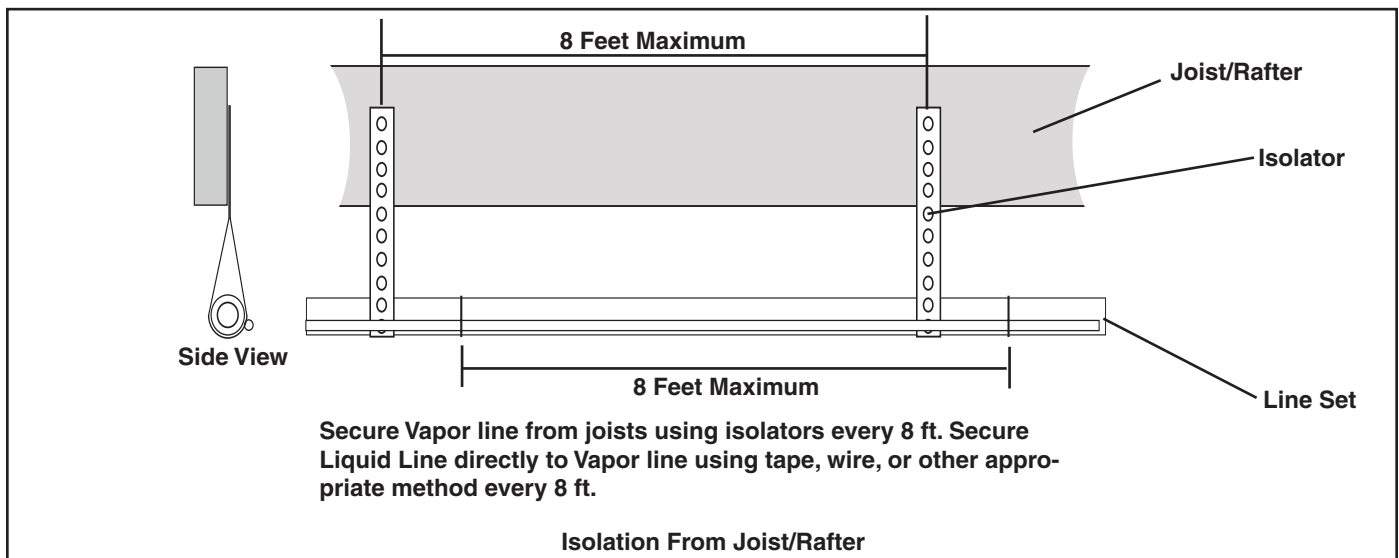

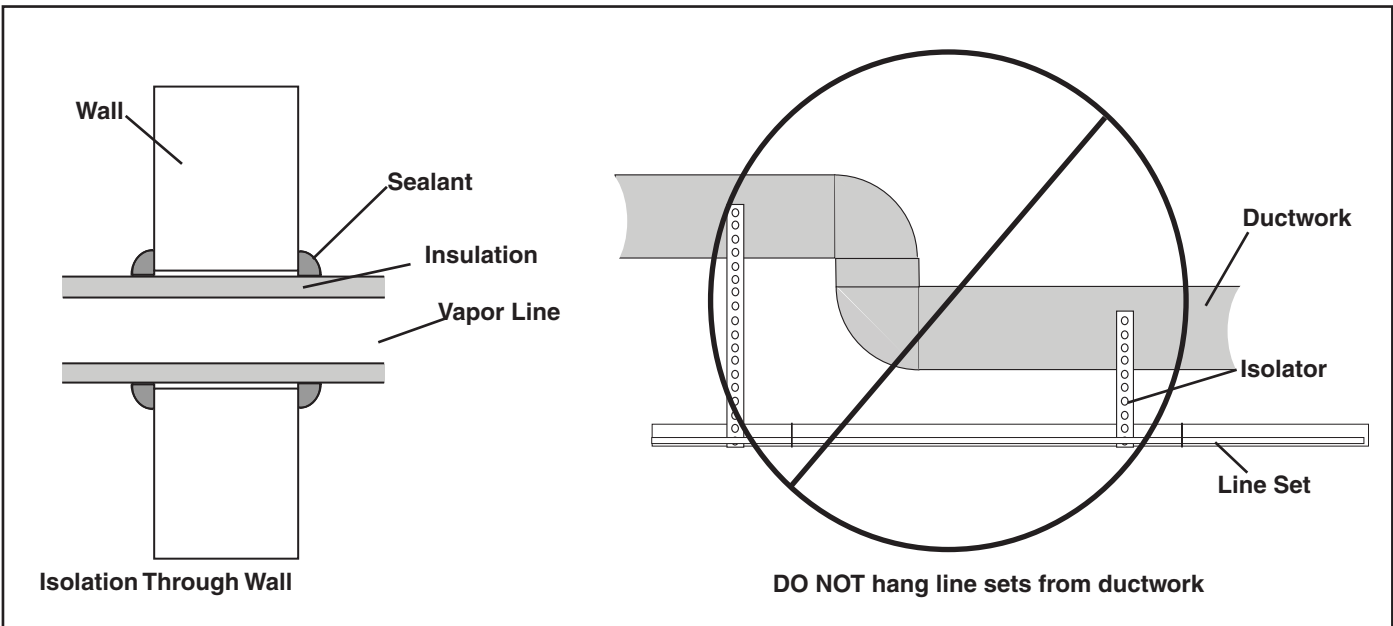
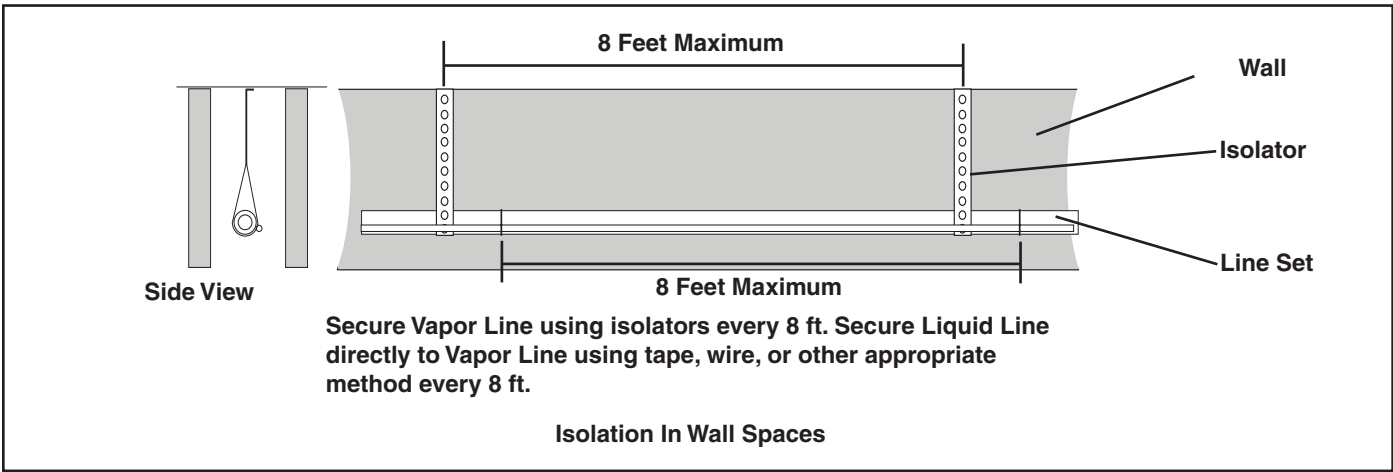

Section 7. Refrigerant Line Brazing

7.1 Braze The Refrigerant Lines

STEP 1 - Remove caps or plugs. Use a deburring tool to deburr the pipe ends. Clean both internal and external surfaces of the tubing using an emery cloth.

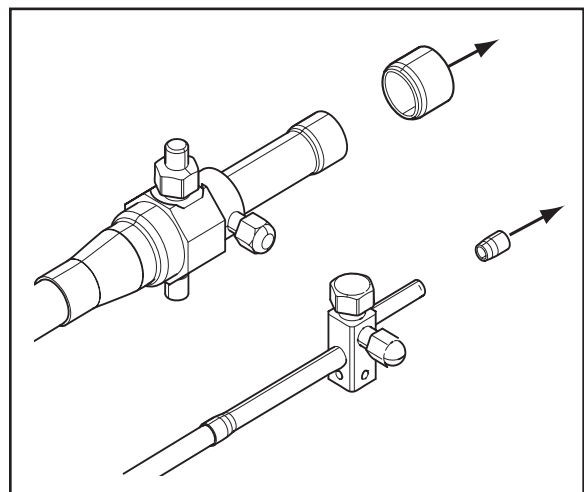

STEP 2 - Remove the pressure tap cap and valve cores from both service valves.

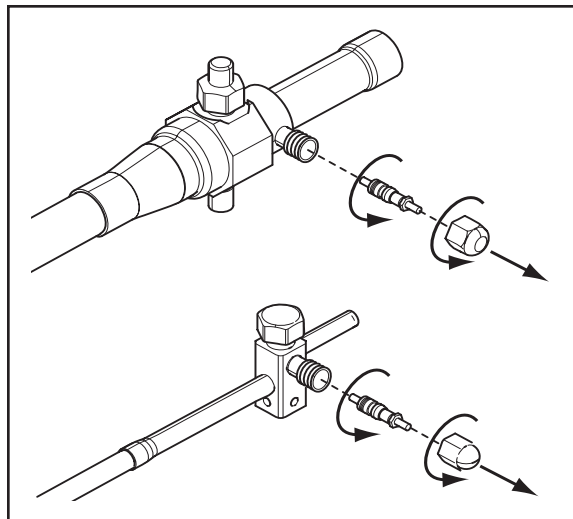

STEP 3 - Purge the refrigerant lines and indoor coil with dry nitrogen.

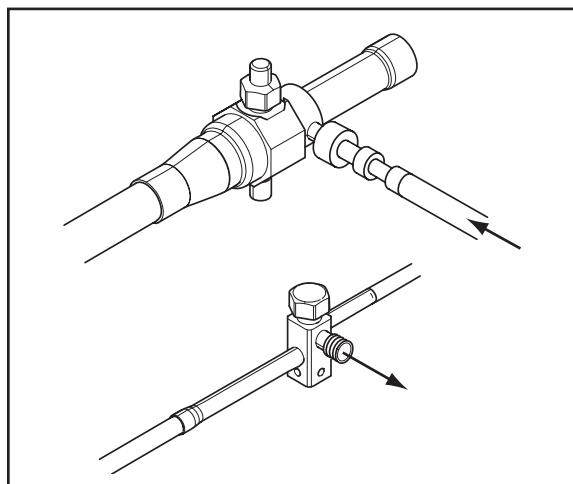

STEP 4 - Wrap a wet rag around the valve body to avoid heat damage and continue the dry nitrogen purge.

Braze the refrigerant lines to the service valves.

Continue the dry nitrogen purge. Do not remove the wet rag until all brazing is completed.

Important: Remove the wet rag before stopping the dry nitrogen purge.

NOTE: Precautions should be taken to avoid heat damage to basepan during brazing. It is recommended to keep the flame directly off of the basepane.

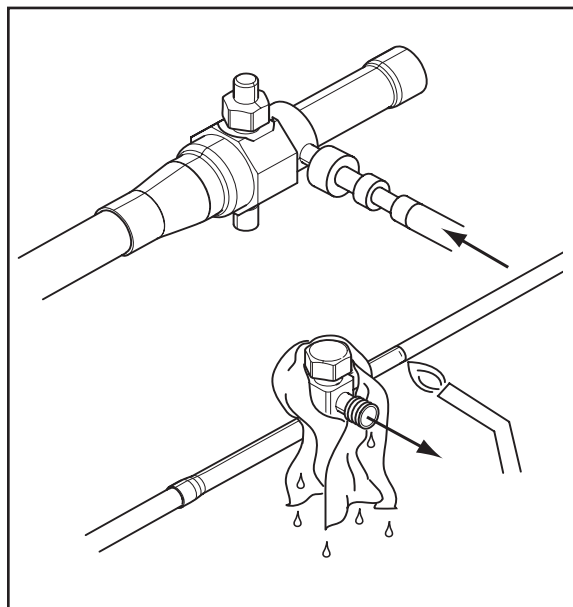

STEP 5 - Replace the pressure tap valve cores after the service valves have cooled.

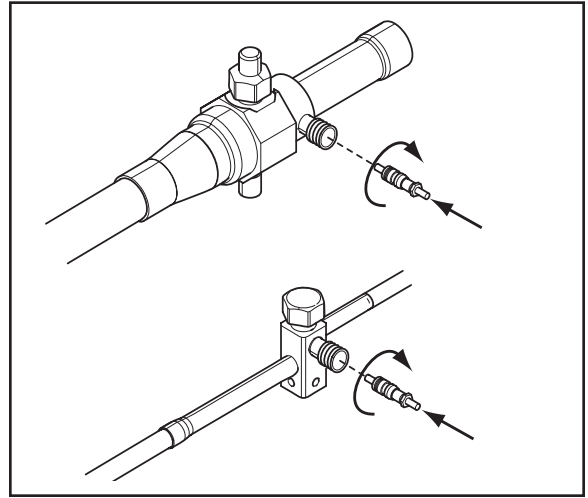

Section 8. Refrigerant Line Leak Check

8.1 Check For Leaks

STEP 1 - Pressurize the refrigerant lines and evaporator coil to 150 PSIG using dry nitrogen.

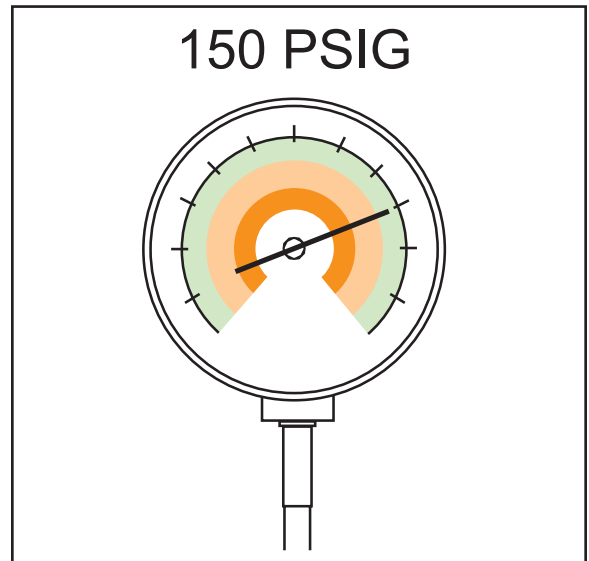

STEP 2 - Check for leaks by using a soapy solution or bubbles at each brazed location.

Remove nitrogen pressure and repair any leaks before continuing.

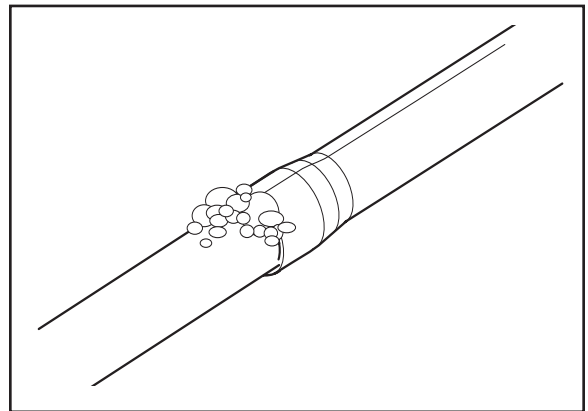

Section 9. Evacuation

9.1 Evacuate the Refrigerant Lines and Indoor Coil

Important: Do not open the service valves until the refrigerant lines and indoor coil leak check and evacuation are complete.

STEP 1 - Evacuate until the micron gauge reads no higher than 350 microns, then close off the valve to the vacuum pump.

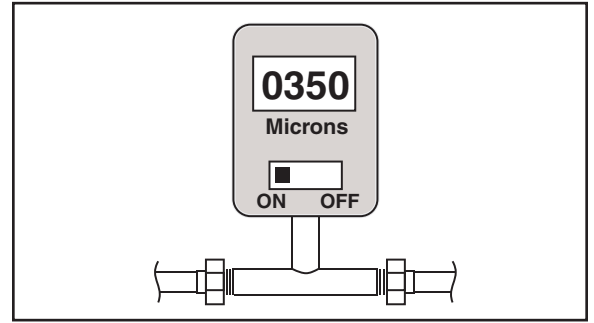

STEP 2 - Observe the micron gauge. Evacuation is complete if the micron gauge does not rise above 500 microns in one (1) minute.

Once evacuation is complete blank off the vacuum pump and micron gauge, and close the valves on the manifold gauge set.



Section 10. Service Valves

10.1 Open the Gas Service Valve

Important: Leak check and evacuation must be completed before opening the service valves.

NOTE: Do not vent refrigerant gases into the atmosphere

STEP 1 - Remove valve stem cap.

STEP 2 - Using an adjustable wrench, turn valve stem 1/4 turn counterclockwise to the fully open position.

STEP 3 - Replace the valve stem cap to prevent leaks. Tighten finger tight plus an additional 1/6 turn.

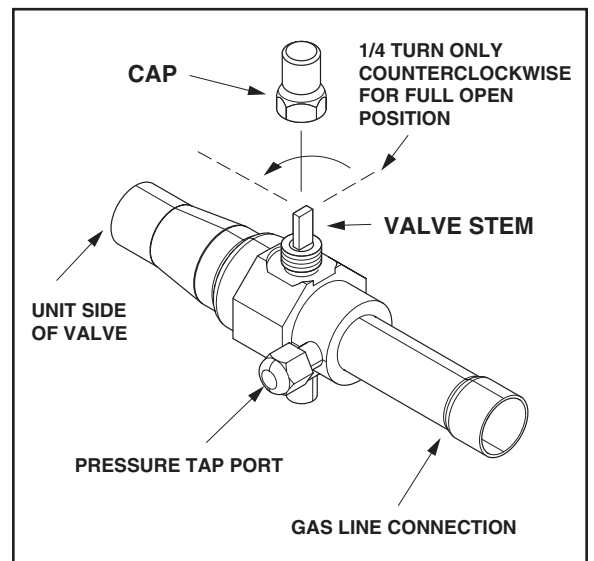

10.1 Open the Liquid Service Valve

WARNING

Extreme caution should be exercised when opening the Liquid Line Service Valve. Turn counterclockwise until the valve stem just touches the rolled edge. No torque is required. Failure to follow this warning will result in abrupt release of system charge and may result in personal injury and /or property damage.

Important: Leak check and evacuation must be completed before opening the service valves.

STEP 1 - Remove service valve cap.

STEP 2 - Fully insert 3/16" hex wrench into the stem and back out counterclockwise until valve stem just touches the rolled edge (approximately five (5) turns.)

STEP 3 - Replace the valve cap to prevent leaks. Tighten finger tight plus an additional 1/6 turn.

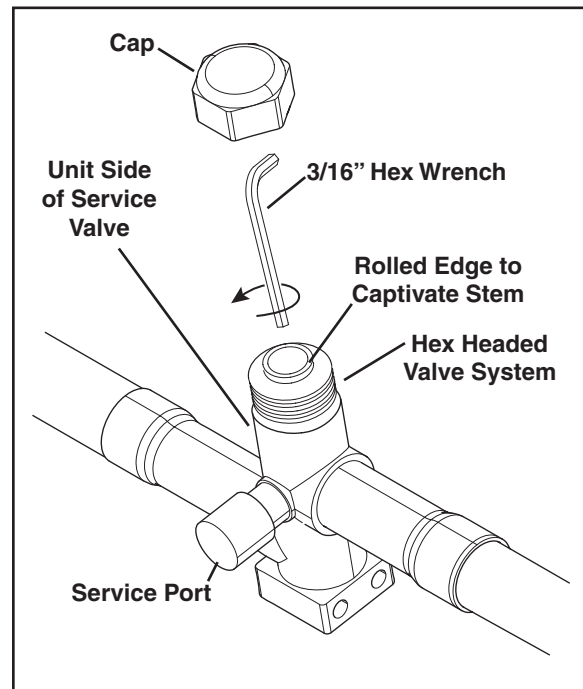

Section 11. Electrical - Low Voltage

11.1 Low Voltage Maximum Wire Length

Table 11.1 defines the maximum total length of low voltage wiring from the outdoor unit, to the indoor unit, and to the thermostat.

| 24 VOLTS | |
|-----------|------------------|
| WIRE SIZE | MAX. WIRE LENGTH |
| 18 AWG | 150 Ft. |
| 16 AWG | 225 Ft. |
| 14 AWG | 300 Ft. |

11.2 Low Voltage Hook-up Diagrams

4TEE3F31-66 Variable Speed Air Handler Hook-up Diagram

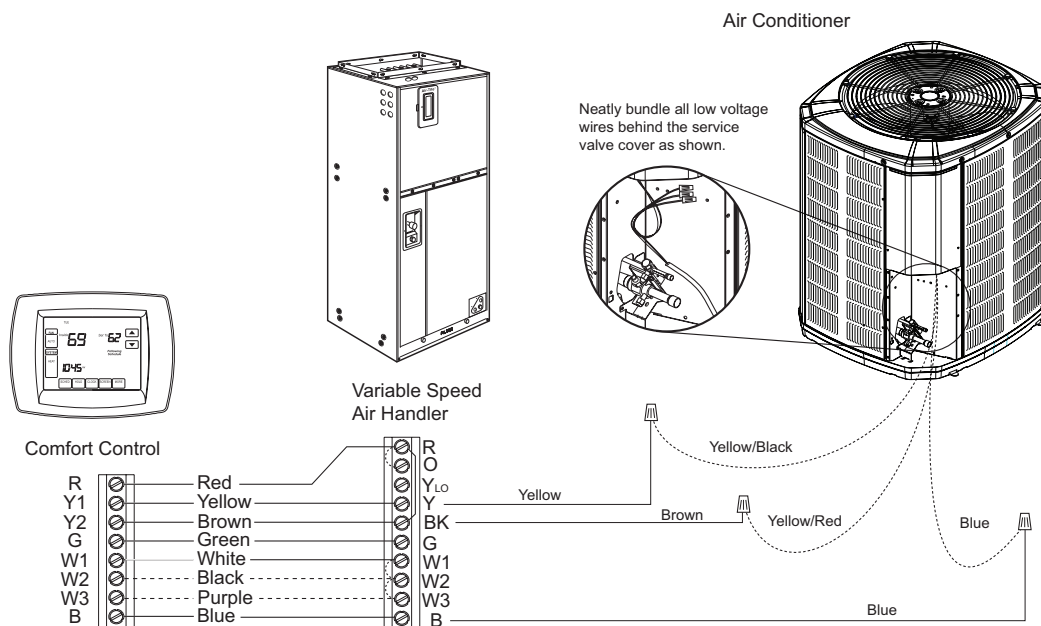

Notes:

1. If electric heat does not have 3rd contactor (CH), connect a jumper wire from W3 to W2. If electric heat does not have 2nd contactor (BH), connect a jumper wire from W2 to W1.
2. Installer must remove the factory installed jumper between R and BK on the air handler terminal strip.
3. Installer must add a field installed jumper between R and O on the air handler terminal strip.
4. 4A7A6 units require 80% airflow with Y1 (low stage) and 100% airflow with Y2 (high stage).
 - A) Connect Y1 from comfort control to Y at the VS air handler and to Y1 (yellow/black) at the HP.
 - B) Connect Y2 from comfort control to BK at the VS air handler and to Y2 (yellow/red) at the HP.
5. Comfort control may not have W2 or W3 terminals.

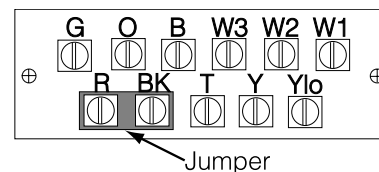

Communicating Indoor Unit with 24 V Control Hook-up Diagram

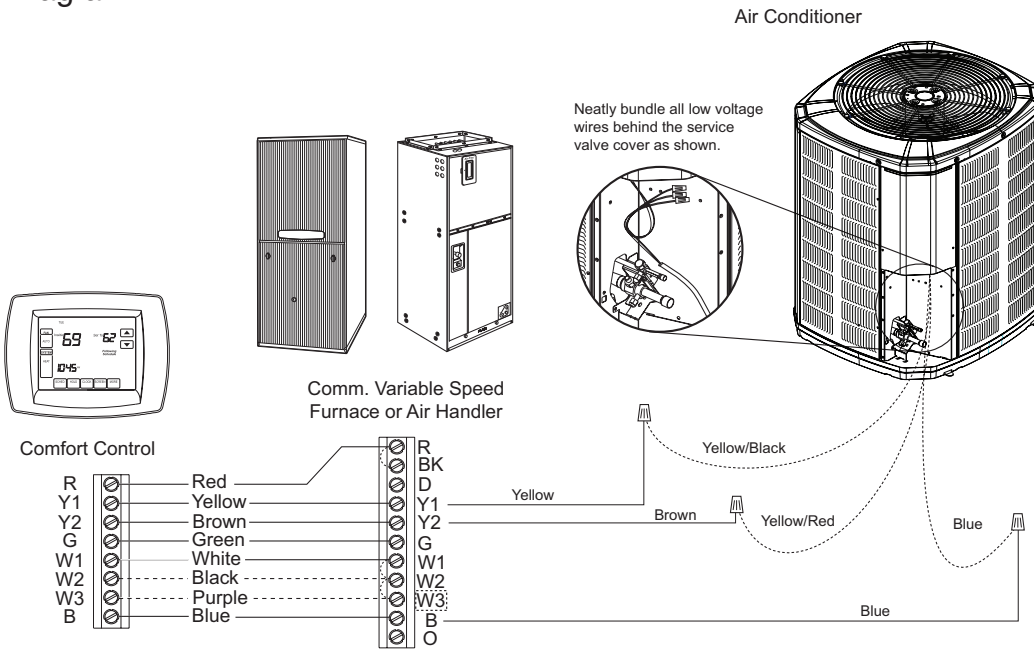

*AM7 Air Handler Hook-up Diagram

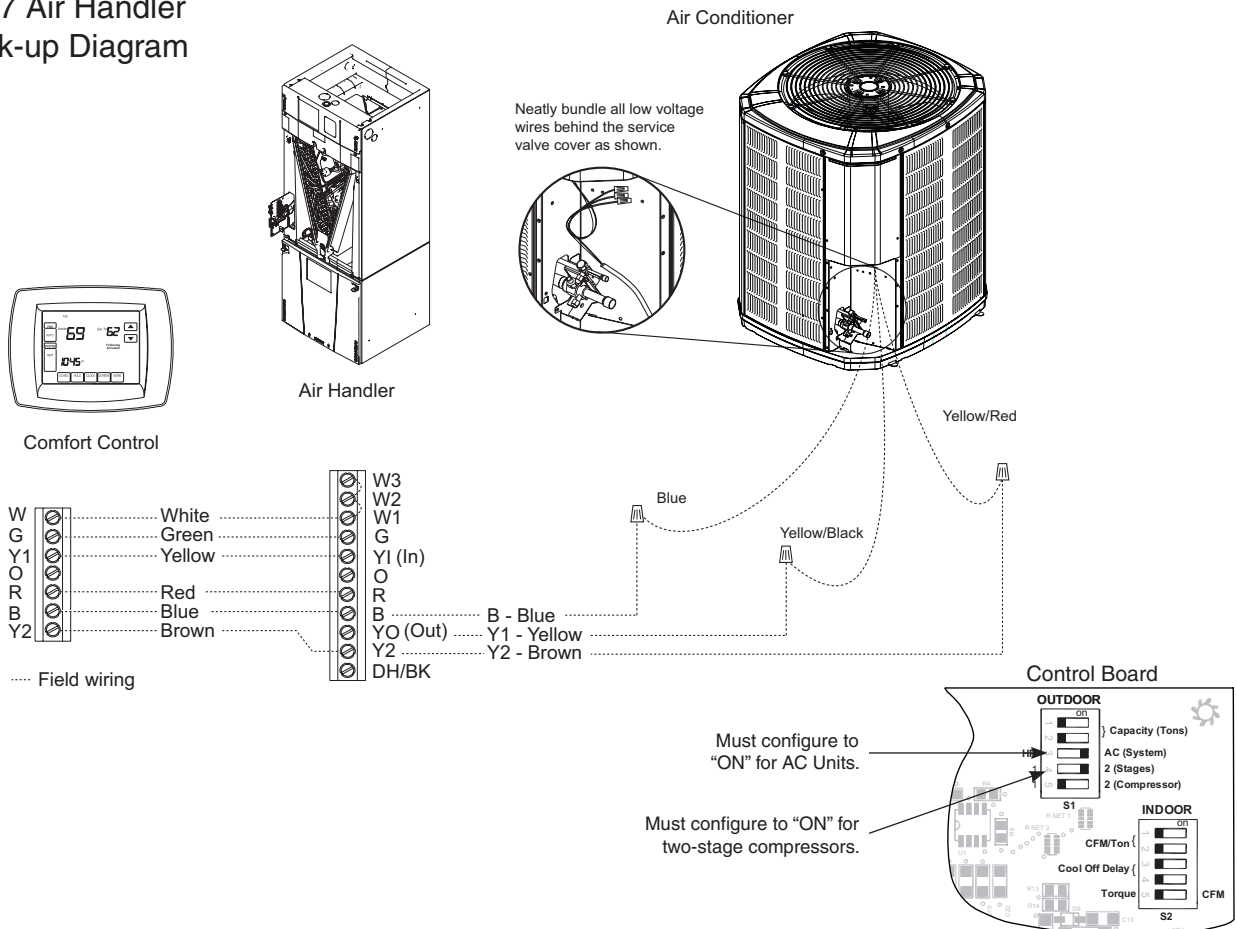

Variable Speed Furnace Hook-up Diagram

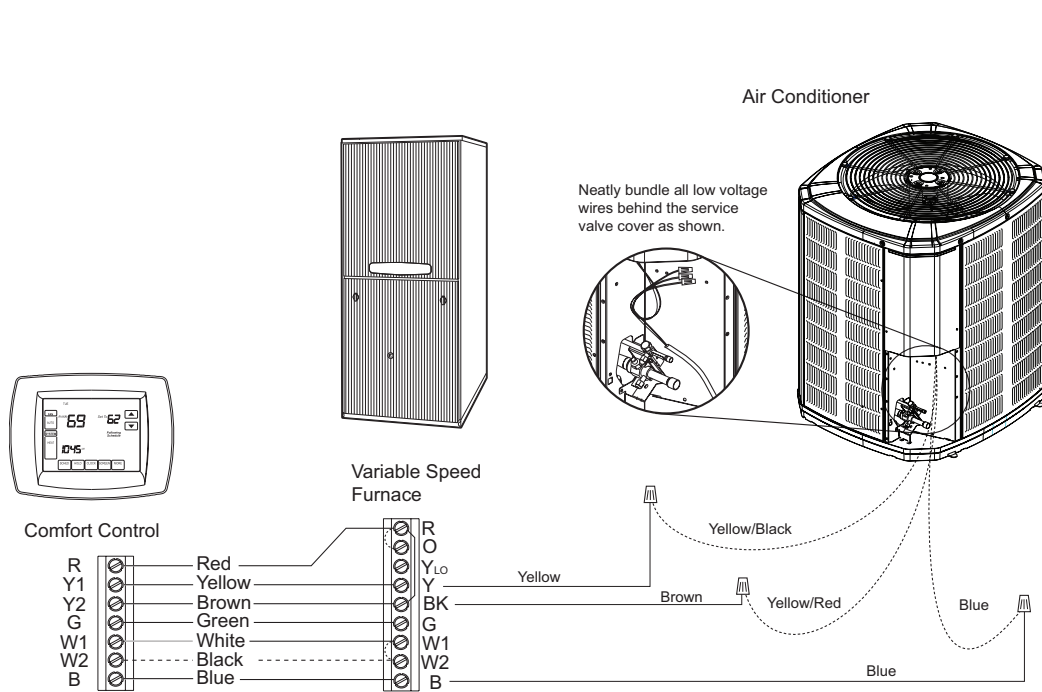

Notes:

1. Installer must cut the factory R to BK jumper on furnace circuit board. OR, on new 15-digit models, set the S5-2 DIP switch to OFF.
2. Installer must add a field installed jumper between R and O on the furnace terminal strip
3. 4A7A6 units require 80% airflow with Y1 (low stage) and 100% airflow with Y2 (high stage).
 - A) Connect Y1 from comfort control to Y at the VS furnace and to Y1 (yellow/black) at the HP.
 - B) Connect Y2 from comfort control to BK at the VS furnace and to Y2 (yellow/red) at the HP.
4. Comfort control may not have W2 or W3 terminals.
5. If single stage heating comfort control is used, jumper W1 to W2 on the furnace terminal strip.

Section 12. Electrical - High Voltage

12.1 High Voltage Power Supply

⚠ WARNING

LIVE ELECTRICAL COMPONENTS!

During installation, testing, servicing, and troubleshooting of this product, it may be necessary to work with live electrical components. Failure to follow all electrical safety precautions when exposed to live electrical components could result in death or serious injury.

The high voltage power supply must agree with the equipment nameplate.

Power wiring must comply with national, state, and local codes.

Follow instructions on unit wiring diagram located on the inside of the control box cover and in the Service Facts document included with the unit.

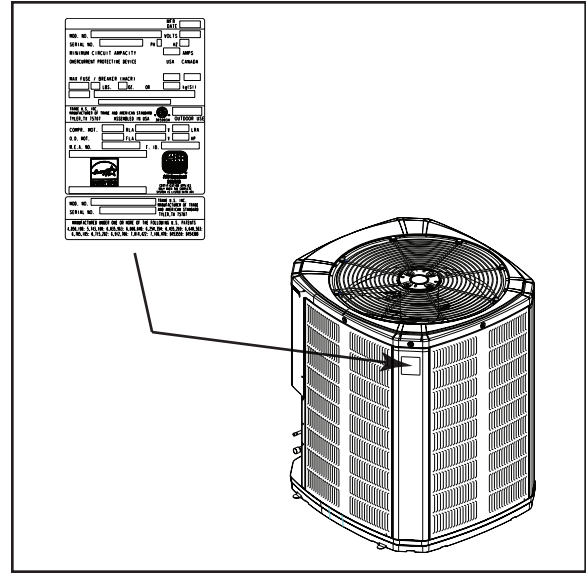

12.2 High Voltage Disconnect Switch

Install a separate disconnect switch at the outdoor unit.

For high voltage connections, flexible electrical conduit is recommended whenever vibration transmission may create a noise problem within the structure.

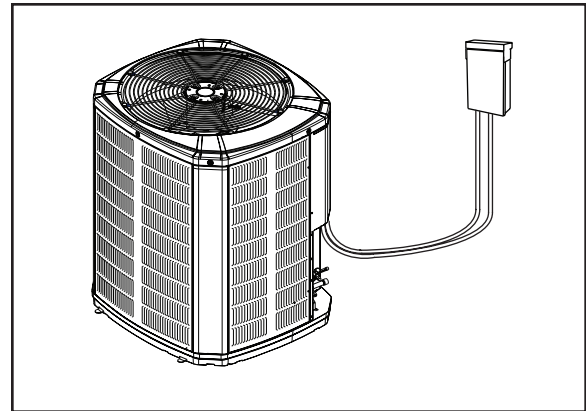

12.3 High Voltage Ground

Ground the outdoor unit per national, state, and local code requirements.

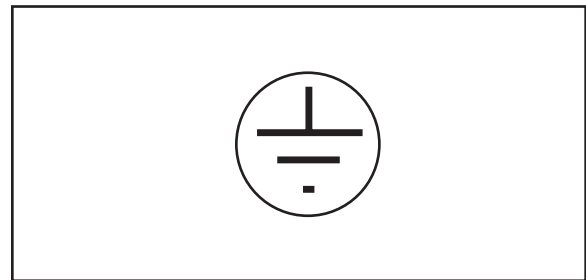

Section 13. Start Up

13.1 System Start Up

STEP 1 - Ensure Sections 7 through 12 have been completed.

STEP 2 - Set System Thermostat to OFF.

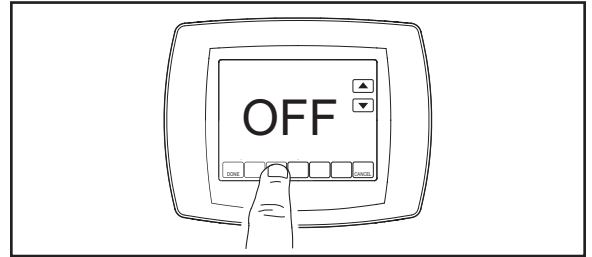

STEP 3 - Turn on disconnect(s) to apply power to the indoor and outdoor units.

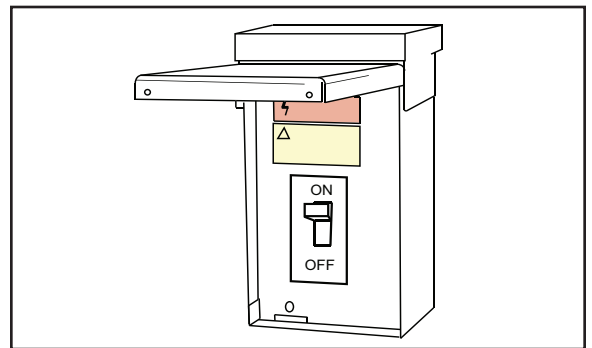

STEP 4 - Wait one (1) hour before starting the unit if compressor crankcase heater accessory is used and the Outdoor Ambient is below 70°F.



STEP 5 - Set system thermostat to ON.

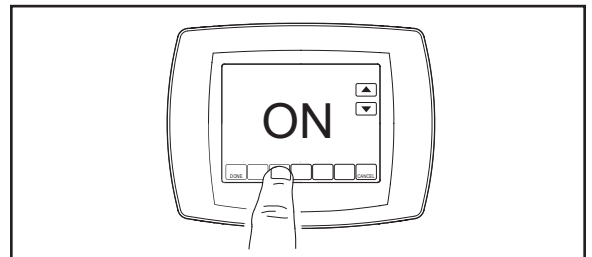

Section 14. System Charge Adjustment

14.1 Temperature Measurements

STEP 1 - Check the outdoor temperatures.

Subcooling (in cooling mode) is the only recommended method of charging above 55° F ambient outdoor temperature.

For best results the indoor temperature should be kept between 70° F to 80° F.

Note: It is important to return in the spring or summer to accurately charge the system in the cooling mode when outdoor ambient temperature is above 55° F.

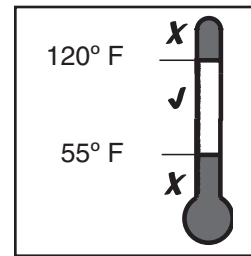

Outdoor Temp

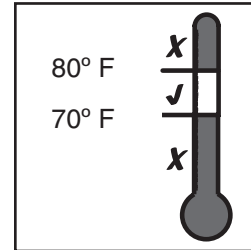

Indoor Temp

14.2 Subcooling Charging in Cooling (Above 55° F Outdoor Temp.)

STEP 1 - Use the refrigerant line total length and lift measurements from Section 5.3.

Total Line Length = _____ Ft.

Vertical Change (Lift) = _____ Ft.

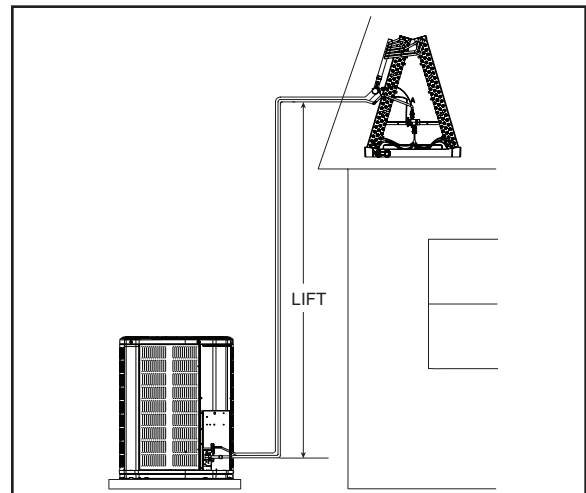

STEP 2 - Determine the final subcooling value using total Line Length and Lift measured in STEP 1 and the charts below.

2 Ton Unit

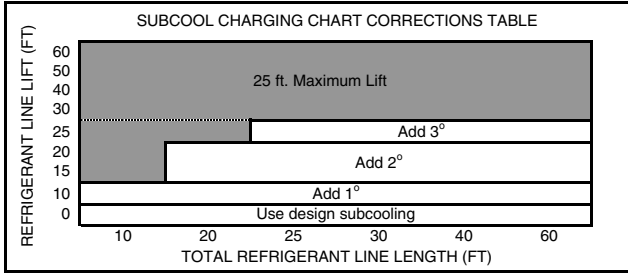

3 Ton Unit

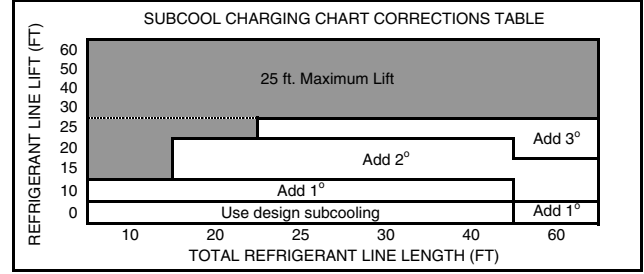

4 Ton Unit

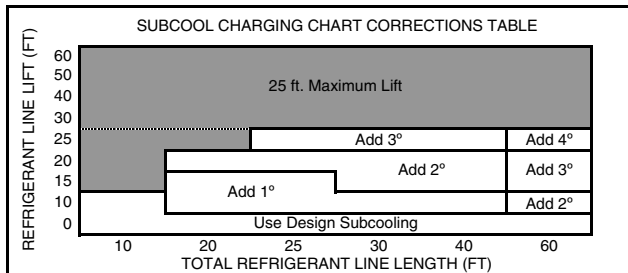

5 Ton Unit

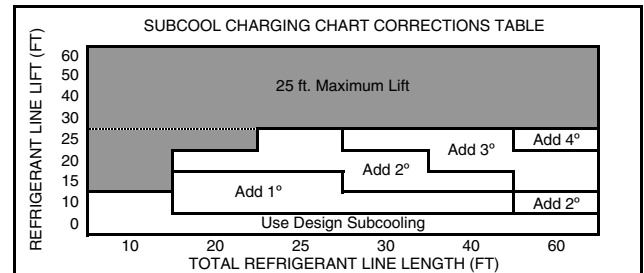

Design Subcooling Value = _____ ° F
(from nameplate or Service Facts)

Subcooling Correction = _____ ° F

Final Subcooling Value = _____ ° F

STEP 3 - Stabilize the system by operating for a minimum of 20 minutes.

At startup, or whenever charge is removed or added, the system must be operated for a minimum of 20 minutes to stabilize before accurate measurements can be made.



STEP 4 - Measure the liquid line temperature and pressure at the outdoor unit's service valve.

Measured Liquid Line Temp = _____ ° F

Liquid Gage Pressure = _____ PSI

Final Subcooling Value = _____ ° F

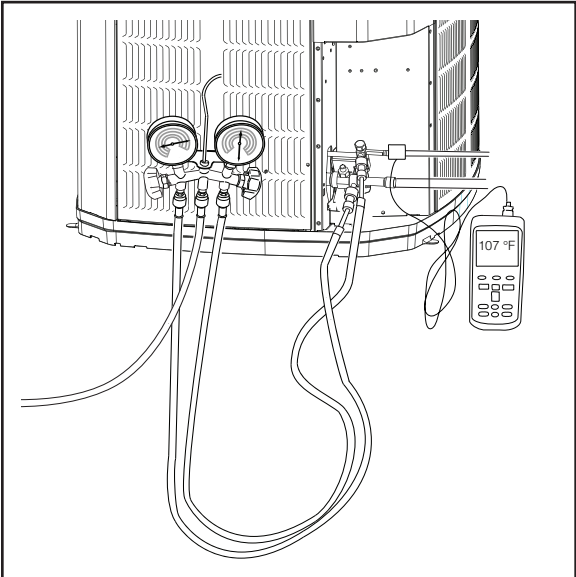

STEP 5 - Use the final subcooling value, refrigerant temperature and pressure from STEP 4, to determine the proper liquid gage pressure using Table 14.2.

Example: Assume a 12° F Final Subcooling value and liquid temp of 90° F.

1. Locate 12° F Final Subcooling in Table 14.2.
2. Locate the Liquid Temperature (90° F) in the left column.
3. The Liquid Gage Pressure should be approximately 327 PSI. (This is shown as the intersection of the Final Subcooling column and the Liquid Temperature row.

Table 14.2

| R-410A REFRIGERANT CHARGING CHART | | | | | | | |
|-----------------------------------|-----------------------|-----|-----|-----|-----|-----|-----|
| LIQUID TEMP (°F) | FINAL SUBCOOLING (°F) | | | | | | |
| | 8 | 9 | 10 | 11 | 12 | 13 | 14 |
| LIQUID GAGE PRESSURE (PSI) | | | | | | | |
| 55 | 179 | 182 | 185 | 188 | 191 | 195 | 198 |
| 60 | 195 | 198 | 201 | 204 | 208 | 211 | 215 |
| 65 | 211 | 215 | 218 | 222 | 225 | 229 | 232 |
| 70 | 229 | 232 | 236 | 240 | 243 | 247 | 251 |
| 75 | 247 | 251 | 255 | 259 | 263 | 267 | 271 |
| 80 | 267 | 271 | 275 | 279 | 283 | 287 | 291 |
| 85 | 287 | 291 | 296 | 300 | 304 | 309 | 313 |
| 90 | 309 | 313 | 318 | 322 | 327 | 331 | 336 |
| 95 | 331 | 336 | 341 | 346 | 351 | 355 | 360 |
| 100 | 355 | 360 | 365 | 370 | 376 | 381 | 386 |
| 105 | 381 | 386 | 391 | 396 | 402 | 407 | 413 |
| 110 | 407 | 413 | 418 | 424 | 429 | 435 | 441 |
| 115 | 435 | 441 | 446 | 452 | 458 | 464 | 470 |
| 120 | 464 | 470 | 476 | 482 | 488 | 495 | 501 |
| 125 | 495 | 501 | 507 | 514 | 520 | 527 | 533 |

From Dwg. D154557P01 Rev. 3

STEP 6 - Adjust refrigerant level to attain proper gage pressure.

Add refrigerant if the Liquid Gage Pressure is lower than the chart value.

1. Connect gages to refrigerant bottle and unit as illustrated.
2. Purge all hoses.
3. Open bottle.
4. Stop adding refrigerant when liquid line temperature and Liquid Gage Pressure matches the charging chart Final Subcooling value.

Recover refrigerant if the Liquid Gage Pressure is higher than the chart value.

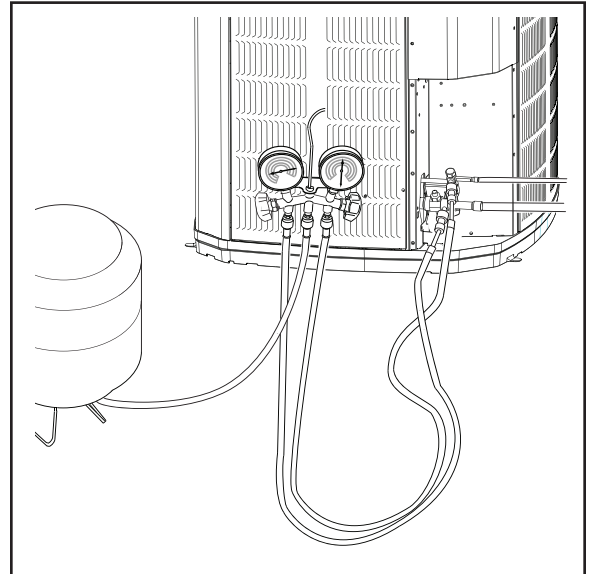

STEP 7 - Stabilize the system.

1. Wait 20 minutes for the system condition to stabilize between adjustments.

Note: When the Liquid Line Temperature and Gage Pressure approximately match the chart, the system is properly charged.

2. Remove gages.
3. Replace service port caps to prevent leaks. Tighten finger tight plus an additional 1/6 turn.



STEP 8 - Verify typical performance.

Refer to System Pressure Curves in the Service Facts to verify typical performance.

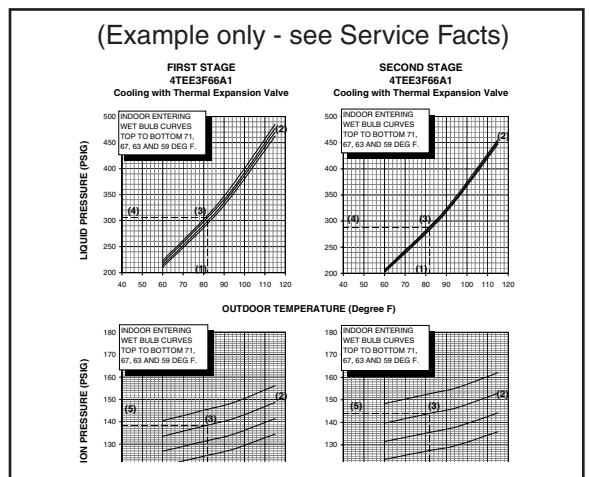

STEP 9 - Record System Information for reference.

Record system pressures and temperatures after charging is complete.

Outdoor model number = _____

Measured Suction Line Temp = _____ ° F

Measured Outdoor Ambient = _____ ° F

Liquid Gage Pressure = _____ PSI

Measured Indoor Ambient = _____ ° F

Suction Gage Pressure = _____ PSI

Measured Liquid Line Temp = _____ ° F

Section 15. Checkout Procedures and Troubleshooting

15.1 Operational And Checkout Procedures

Final phases of this installation are the unit Operational and Checkout Procedures. To obtain proper performance, all units must be operated and charge adjustments made.

Important: Perform a final unit inspection to be sure that factory tubing has not shifted during shipment. Adjust tubing if necessary so tubes do not rub against each other when the unit runs. Also be sure that wiring connections are tight and properly secured.

CHECKOUT PROCEDURE

After installation has been completed, it is recommended that the entire system be checked against the following list:

- | | |
|--|--|
| 1. Leak check refrigerant lines. [] | 7. Be sure that indoor coil drain line drains freely. Pour water into drain pan..... [] |
| 2. Properly insulate suction lines and fittings..... [] | 8. Be sure that supply registers and return grilles are open and unobstructed..... [] |
| 3. Properly secure and isolate all refrigerant lines..... [] | 9. Be sure that a return air filter is installed..... [] |
| 4. Seal passages through masonry. If mortar is used, prevent mortar from coming into direct contact with copper tubing..... [] | 10. Be sure that the correct airflow setting is used. (Indoor blower motor) [] |
| 5. Verify that all electrical connections are tight..... [] | 11. Operate complete system in each mode to ensure safe operation..... [] |
| 6. Observe outdoor fan during on cycle for clearance and smooth operation..... [] | |

15.2 Troubleshooting

| SYSTEM FAULTS | WHAT TO CHECK | | | | | | | | | | | | | | | | | | | | |
|--|---------------|--------|--------|--------|--------|--------|--------|--------|--------|--------|--------|--------|--------|--------|--------|--------|--------|--------|--------|--------|---|
| | MODE | WIRING | WIRING | WIRING | WIRING | WIRING | WIRING | WIRING | WIRING | WIRING | WIRING | WIRING | WIRING | WIRING | WIRING | WIRING | WIRING | WIRING | WIRING | WIRING | |
| REFRIGERANT CIRCUIT | | | | | | | | | | | | | | | | | | | | | |
| Head Pressure Too High | C | | | | | | | | | | | | | | | | | | P | P | S |
| | H | | | | | | | | | | | | | | | | | | | P | S |
| Head Pressure Too Low | C | | | | | | | | | | | | | | | | | | S | P | |
| | H | | | | | | | | | | | | | | | | | | S | P | |
| Suction Pressure Too High | C | | | | | | | | | | | | | | | | | | S | P | P |
| | H | | | | | | | | | | | | | | | | | | S | P | P |
| Suction Pressure Too Low | C | | | | | | | | | | | | | | | | | | P | | |
| | H | | | | | | | | | | | | | | | | | | P | | |
| Liquid Refrig. Floodback (TXV/EEV) | C | | | | | | | | | | | | | | | | | | | | |
| | H | | | | | | | | | | | | | | | | | | | | |
| Liquid Refrig. Floodback (Cap. Tube) | C | | | | | | | | | | | | | | | | | | P | | |
| | H | | | | | | | | | | | | | | | | | | P | | |
| I.D. Coil Frosting | C | | | | | | | | | | | | | | | | | | P | | |
| | H | | | | | | | | | | | | | | | | | | P | | |
| Compressor Runs Inadequate or No Cooling/Htg | C | | | | | | | | | | | | | | | | | | S | P | S |
| | H | | | | | | | | | | | | | | | | | | S | P | S |
| ELECTRICAL | | | | | | | | | | | | | | | | | | | | | |
| Compressor & O.D. Fan Won't Start | C | P | P | | | | | | S | P | S | P | P | | | | | | | | |
| | H | P | P | | | | | | S | P | S | P | P | | | | | | | | |
| Compressor Will Not Start But O.D. Fan Runs | C | | P | S | P | S | S | S | | | | | | | | | | | | P | |
| | H | | P | S | P | S | S | S | | | | | | | | | | | | P | |
| O.D. Fan Won't Start | C | | P | | P | | | S | | | | | | | | | | | | | |
| | H | | P | | P | | | S | | | | | | | | | | | | | |
| Compressor Hums But Won't Start | C | | | | P | S | S | S | | | | | | | | | | | | P | |
| | H | | | | P | S | S | S | | | | | | | | | | | | P | |
| Compressor Cycles on IOL | C | | P | S | P | S | S | S | | | | | | | | | | | P | S | P |
| | H | | P | S | P | S | S | S | | | | | | | | | | | P | S | P |
| I.D. Blower Won't Start | C | P | P | | | | | | S | P | S | | S | | | | | | | | |
| | H | P | P | | | | | | S | P | S | | S | | | | | | | | |
| DEFROST | | | | | | | | | | | | | | | | | | | | | |
| Unit Won't Initiate Defrost | C | | | | | | | | | | | | | | | | | | | | |
| | H | | | | | | | | | | | | | | | | | | | P | P |
| Defrost Terminates on Time | C | | | | | | | | | | | | | | | | | | | | |
| | H | | | | | | | | | | | | | | | | | | P | | P |
| Unit Icing Up | C | | | | | | | | | | | | | | | | | | | | |
| | H | | | | | | | | | | | | | | | | | | P | | P |

C - Cooling H - Heating P - Primary Causes S - Secondary Causes * - 3 Phase Only

American Standard
HEATING & AIR CONDITIONING

6200 Troup Highway
Tyler, TX 75707
www.americanstandardair.com



The manufacturer has a policy of continuous product and product data improvement and it reserves the right to change design and specifications without notice. Representative-only illustrations included in this document.